

Thunderbird Storm

Thunderbird Storm

Table of Contents

Introduction	2
Foreword - Safety First	2
The Motorcycle	2
General Information	3
Pillion Seat	3
Removal	3
Installation	3
Pillion Footrests	4
Removal	4
Installation	5
Maintenance	6
Headlights	6
Headlight Bulb Replacement	7
Specifications	8

Foreword - Safety First

Introduction

This handbook supplement contains information for the Thunderbird Storm model, and includes information on:

- pillion seat removal;
- pillion footrest removal;
- headlight adjustment.

The supplement must be read in conjunction with the accompanying owner's handbook.

All other details are as described in the accompanying owner's handbook.

Always keep this supplement with the owner's handbook, store them with the motorcycle and refer to them whenever necessary.

Foreword - Safety First

The Motorcycle

Warning

This motorcycle is designed for use as a two-wheeled vehicle capable of carrying a rider on his/her own, or a rider and one passenger (subject to the pillion seat and footrests being fitted).

The total weight of the rider, and any passenger, accessories and luggage must not exceed the maximum load limit of 452 lbs (205 kg).

Warning

The footrests provided must always be used by the rider and passenger during operation of the vehicle.

By using the footrests, both rider and passenger will reduce the risk of inadvertent contact with any motorcycle components and will also reduce the risk of injury from entrapment of clothing.

General Information

General Information

Note:

- **Retain all fasteners and removed parts for re-use if the motorcycle is to be returned to its original condition.**

Pillion Seat

Removal

1. Remove the rider and pillion seats as described in the owner's handbook.
2. Insert the M6 plug provided in the rear fixing hole.
3. Remove the pillion seat mounting bracket from the rear fender.

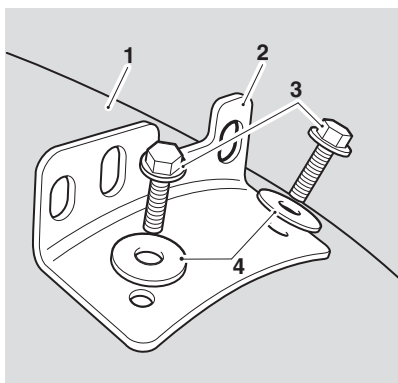

1. **Rear fender**
2. **Pillion seat mounting bracket**
3. **Fixings**
4. **Washers**

4. Insert the two M6 plugs provided in the front fixing holes.

5. Refit the rider's seat as described in the owner's handbook.

Installation

1. Remove the rider's seat as described in the owner's handbook.
2. Remove the three blanking plugs (fitted during removal of the rear seat) from the rear fender.
3. Align the pillion seat mounting bracket to the rear fender and secure with the two fixings and washers.

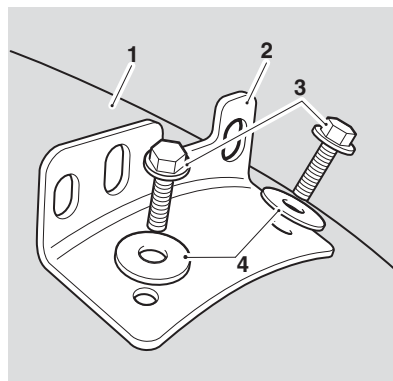

1. **Rear fender**
2. **Pillion seat mounting bracket**
3. **Fixings**
4. **Washers**

4. Tighten the fixings to **9 Nm**.
5. Refit the rider and pillion seats as described in the owner's handbook.

General Information

Pillion Footrests

Removal

Note:

- **The removal procedure is the same for either rear footrest assembly.**

1. Remove both pillion footrest and bracket assemblies, noting that the lower bolt is 15 mm shorter than the upper bolt.

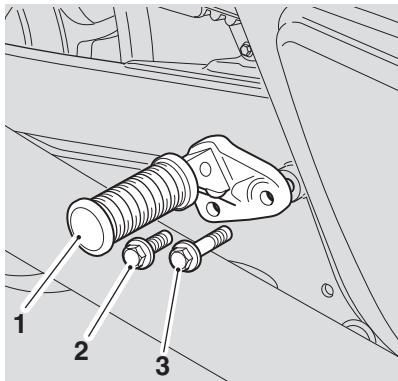

1. Pillion footrest and bracket
2. M10 x 30 mm bolt
3. M10 x 45 mm bolt

Caution

The two pillion footrest bracket bolts are different lengths. Using the longer bolt to secure the silencer bracket to the frame with the pillion footrest removed will result in permanent damage the swinging arm.

2. Secure the silencer bracket to the frame using the M10 x 30 mm bolt through the upper fixing hole. **DO NOT** use the M10 x 45 mm bolt.

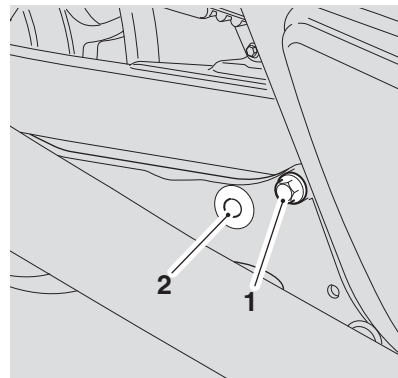

1. M10 x 30 mm bolt
2. M10 plug

3. Tighten the M10 x 30 mm bolt to **40 Nm**.
4. Insert the M10 plug provided in the lower fixing hole.

General Information

Installation

1. Remove the M10 plug from the lower fixing hole.
2. Remove the M10 x 30 mm bolt from the upper fixing hole.
3. Reposition the pillion footrest bracket to the silencer bracket and secure with the M10 x 30 mm bolt in the lower hole, and the M10 x 45 mm bolt in the upper hole.
4. Tighten both bolts to **40 Nm**.

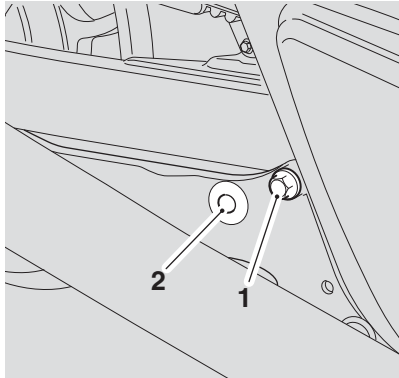

1. M10 x 30 mm bolt
2. M10 plug

Maintenance

Maintenance

Headlights

Warning

Adjust road speed to suit the visibility and weather conditions in which the motorcycle is being operated.

Ensure that the beams are adjusted to illuminate the road surface sufficiently far ahead without dazzling oncoming traffic. An incorrectly adjusted headlight may impair visibility causing an accident.

Warning

Never attempt to adjust a headlamp beam when the motorcycle is in motion.

Any attempt to adjust a headlamp beam when the motorcycle is in motion may result in loss of control and an accident.

Headlight Adjustment - Vertical

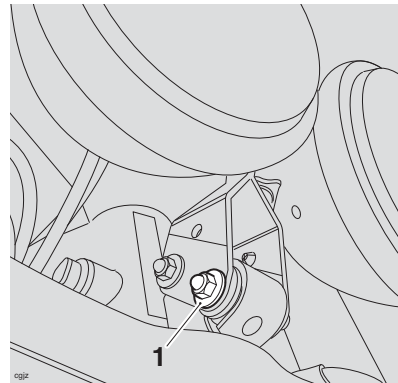

1. Vertical beam adjuster fixings

The vertical beams of the left hand and right hand headlights can only be adjusted together. Independent adjustment is not possible.

Switch the headlight dipped beam on.

Slacken the clamp bolt sufficiently to allow restricted movement of the headlights.

Adjust the position of the headlights to give the required beam setting.

Tighten the clamp bolt to **15 Nm**.

Re-check the headlight beam settings.

Switch the headlights off when both beam settings are satisfactorily set.

Headlight Adjustment - Horizontal

The horizontal beams of both headlights are adjusted as described in the accompanying owner's handbook.

Maintenance

Headlight Bulb Replacement

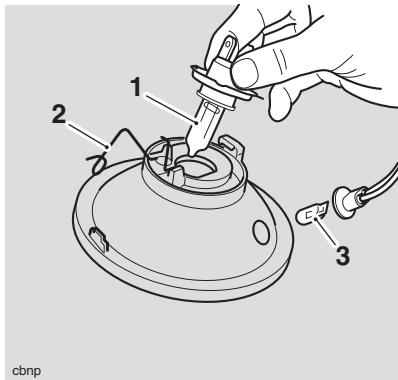

1. Headlight bulb
2. Bulb clip
3. Position lamp bulb

Warning

The bulbs become hot during use. Always allow sufficient time for the bulbs to cool before handling. Avoid touching the glass part of the bulb. If the glass is touched or gets dirty, clean with alcohol before re-use.

Remove the rider's seat.

Disconnect the battery, negative (black) lead first.

Undo the fixing securing the headlight clamp to the headlight body.

Support the headlight while removing the clamp.

Remove the headlight from its bowl while supporting it to prevent the cables from being over-extended.

Disconnect the multi-pin electrical connector from the bulb to be replaced and remove the rubber cover.

Detach the wire retainer from its clip (do not remove the screw) then remove the bulb from the light unit.

Remove the bulb from the headlight unit.

To remove the position lamp bulb:

Without pulling the wires, ease the bulb holder from its socket. The bulb is removed from its holder by pulling gently upwards.

Installation for both bulbs is the reverse of the removal procedure. Tighten the headlamp clamp to **2 Nm**.

Caution

When reconnecting the battery, connect the positive (red) lead first.

Warning

Do not reconnect the battery until the assembly process has been completed. Premature battery reconnection could result in ignition of the battery gases causing risk of injury.

Specifications

Specifications

The specifications are as described in the accompanying owner's handbook, except for the following:

Engine

Displacement	103.7 cu in (1699 cc)
Bore x Stroke	4.22 x 3.71 in (107.1 x 94.3 mm)

Performance

Maximum Power (DIN)	96.7 hp at 5,200 rpm (98 PS at 5,200 rpm)
Maximum Torque	115 lbs ft at 2,950 rpm (156 Nm at 2,950 rpm)

Electrical Equipment

Headlight	2 x 12 Volt, 60/55 watt H4 halogen
-----------	------------------------------------